

Antenna Installation Instructions

Part Number: HW4961-25.5D-HP



Description

This antenna consists of a 0.4 m (1.3 ft) reflector, feeder and mount. The mount is designed to attach the antenna to a vertical pipe of diameter 35mm to 55mm. The mount provides adjustment ranges of $\pm 25^\circ$ fine elevation and $\pm 180^\circ$ azimuth.

Notice

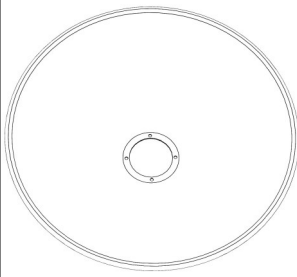
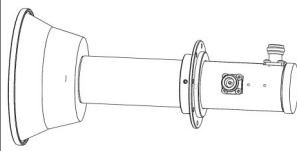
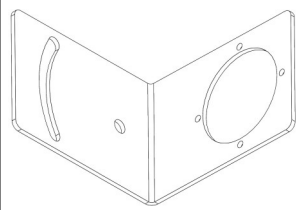
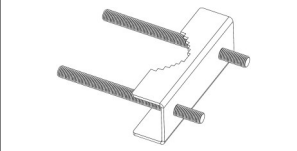
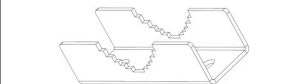
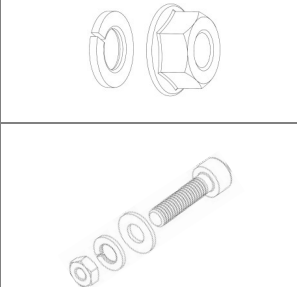

The installation, maintenance or removal of antenna systems requires qualified, experienced personnel. This installation instructions have been written for such personnel. Antenna systems should be inspected once a year by qualified personnel to verify proper installation, maintenance, and condition of equipment. Honorwave disclaims any liability or responsibility for the results of improper or unsafe installation practices.

Part List

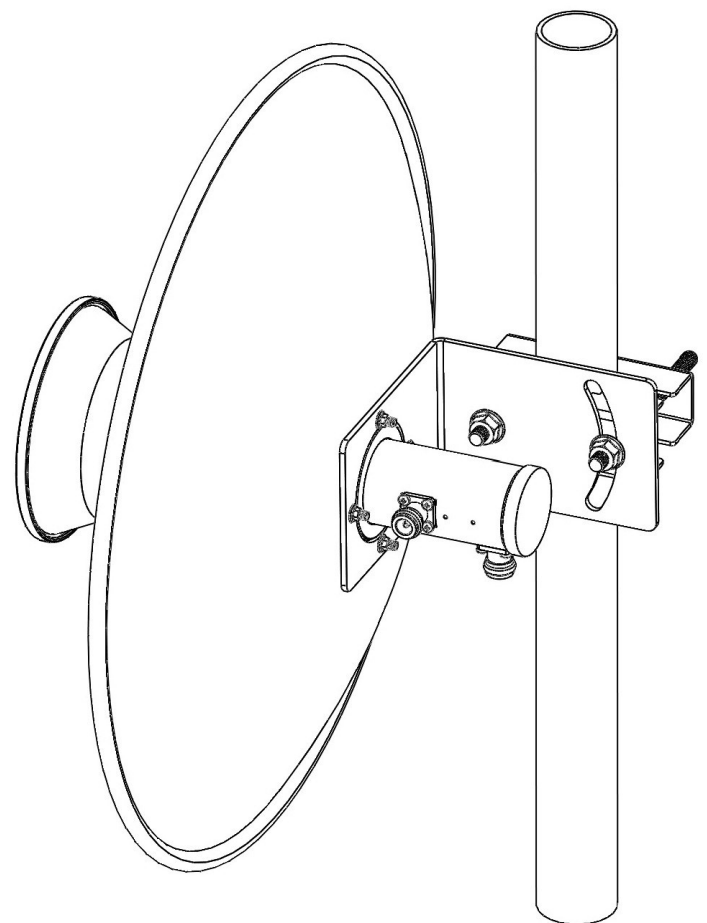
Item	Contents	Qty	Image
A	Reflector 0.4m (1.3ft)	1	
B	Feeder	1	
C	Mounting	1	
D	Pole Bracket	1	
E	Pole Clamp	1	
F	Nut M8, galv	4	
G	Spring Washer M8, galv	4	
H	Screw M4x16, Allen, st	4	
I	Nut M4, galv	4	
J	Spring Washer M4, st	4	
K	Washer M4, st	4	
L	Inasalation Guide	1	



Tools Required

Item	Contents	Qty	Image
1	Combination Wrench, 13mm	1	
2	Combination Wrench, 7mm	1	
3	Allen Wrench, 3mm	1	

Installation

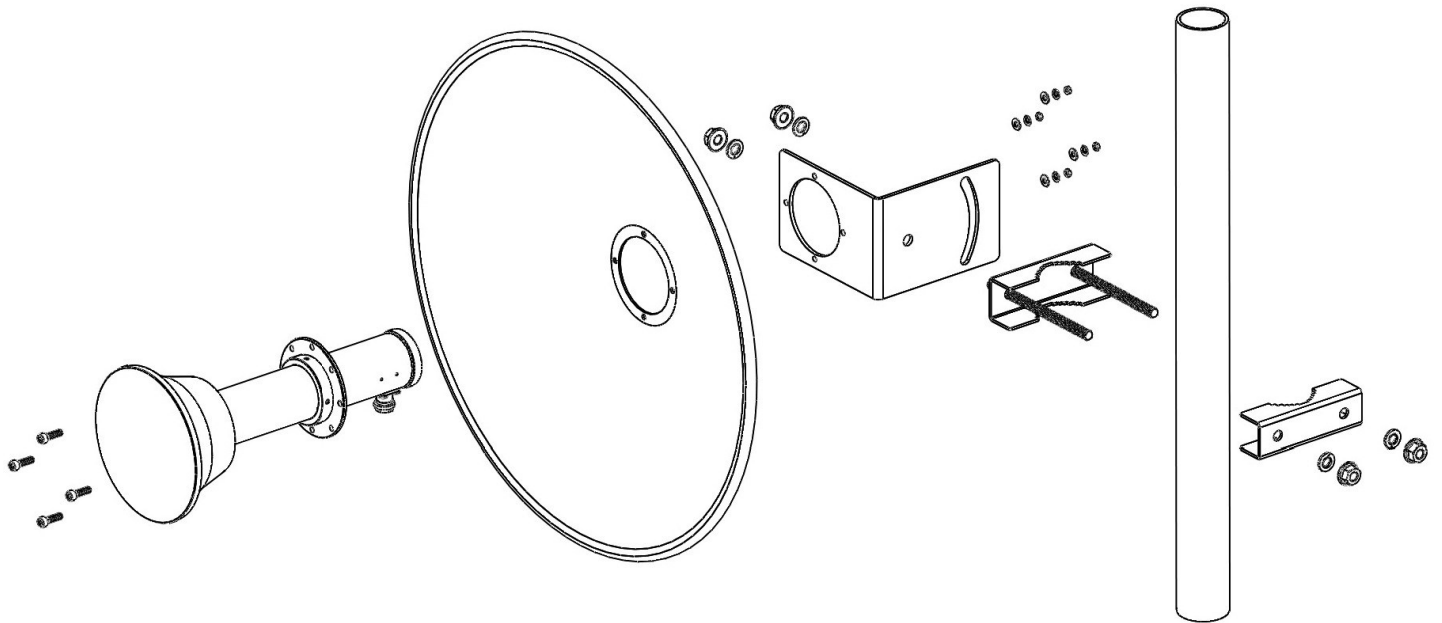

1 Install Mounting and Feed to Reflector

Install Mounting [C] and Feed [B] to Reflector [A] by:

[H] Allen Screw M4x16; 4 pcs

[I] Nut M4; 4 pcs

[J] Spring Washer M4; 4 pcs

[K] Washer M4; 4 pcs

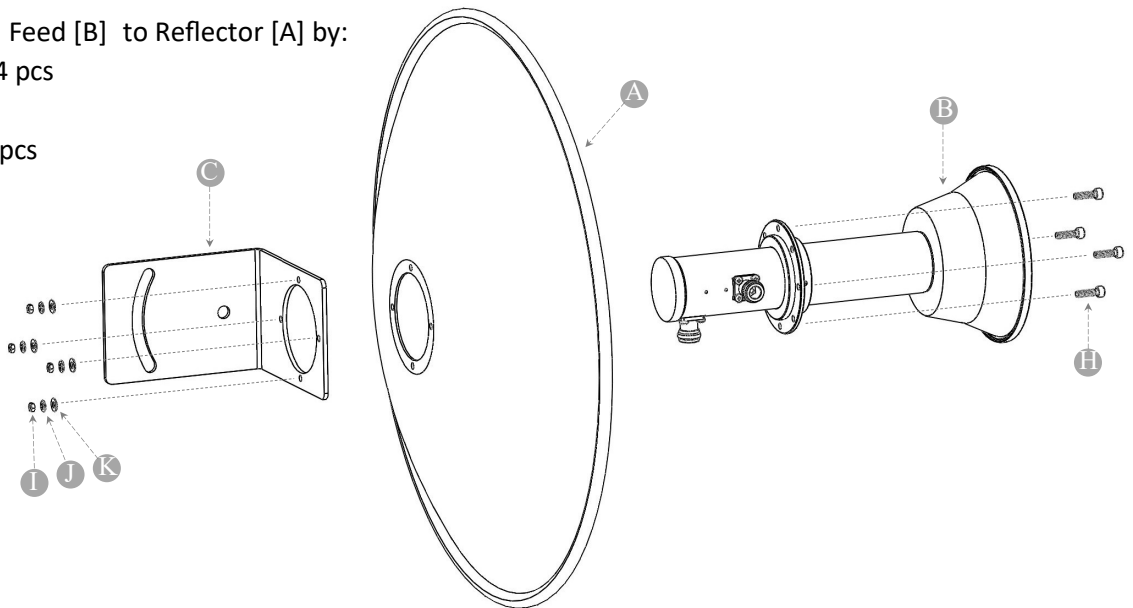

2 Install Pole Bracket to Mounting

Install Pole Bracket [D] to Mounting [C] by:

[F] Nut M8; 2 pcs

[G] Spring Washer M8; 2 pcs

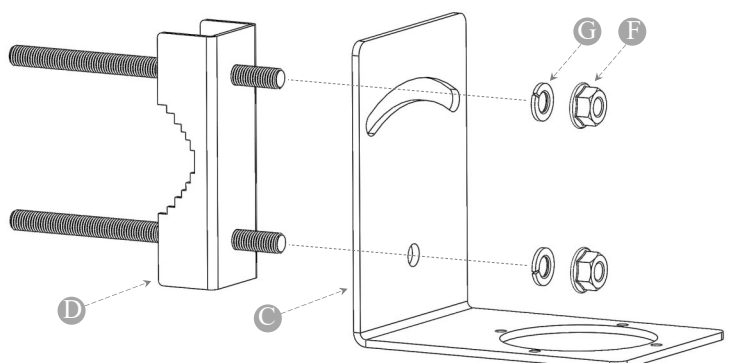

3 Attach Antenna to Mounting Pole

Select location for antenna and attach antenna to mounting pole by:

[E] Pole Clamp; 1 pcs

[F] Nut M8; 2pcs

[G] Spring Washer M8; 2 pcs

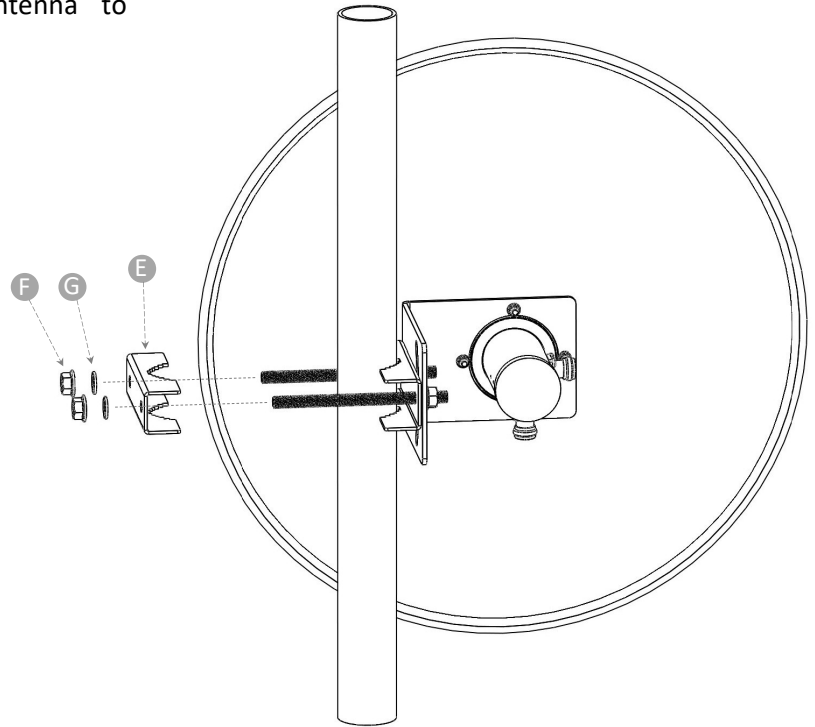

4 Adjust Azimuth and Elevation

After a visual alignment of both elevation and azimuth, elevation and azimuth can be adjusted by rotating the antenna after loosening the nuts M8.

When azimuth/elevation are set tighten nuts to approximately 14N-m (10 lb-ft).

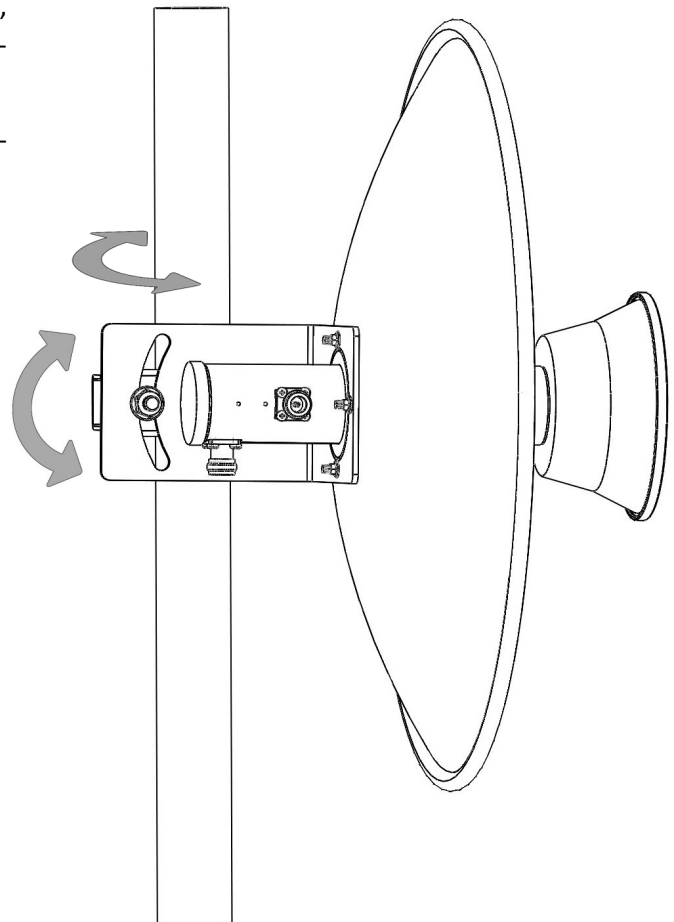

TECHNICAL DATA SHEET

General Specifications

Model Number	HW4961-25.5D-HP
Diameter (ft/m)	1.3/0.4
Polarization	Dual (Vertical and Horizontal)

Electrical Specifications

Input	2 × N-Female
Frequency Range	5 GHz ISM Band
VSWR	1.4:1
Impedance (Ω)	50
Gain (dBi)	25.5
3dB Beamwidth	H-plane: 7.7° / E-plane: 7.7°
F/B Ratio (dB)	30

Mechanical Specifications

Weight With Holder (kg)	2
Color	Golden
Plating	Dacromet
Screws and Nuts	Dacromet
Fine Azimuth Adjustment	$\pm 25^\circ$
Wind Loading (km/h)	200
Operating Temperature	-40 °C to 60 °C
Supportable Comparative Damp	90%

Patterns

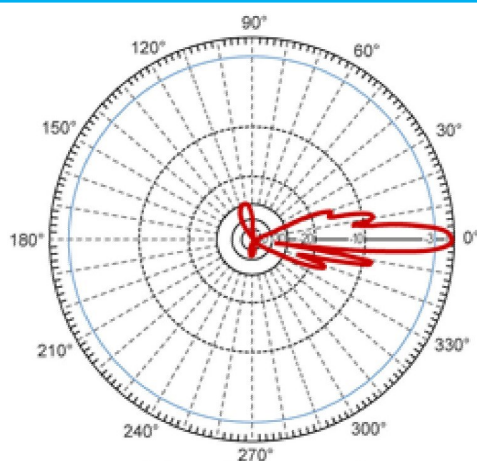

E-Plane

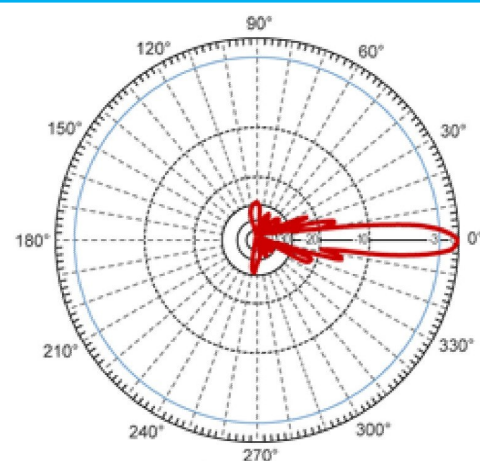

H-Plane

For further technical support leave message at

E-mail: support@honorwave.com

whatsapp: +964 770 607 7724 8 A.M - 5 P.M (GMT+3)

All messages will be answered in 2 working days.