

# Antenna Installation Instructions

Part Number: HW4961-32.65D-HP

## Description



This antenna consists of a 0.9 m (3 ft) reflector, feeder and antenna mounting bracket. The mounting bracket is designed for installation on vertical pipe of diameter 35mm to 75mm. The precise antenna mounting bracket provides adjustment ranges of  $\pm 19^\circ$  fine elevation and  $\pm 11^\circ$  fine azimuth. Unique feature of honorwave mounting bracket is the "Radio Installation Plate". This plate makes it easy to align antenna while radio is installed on the mount.

## Notice

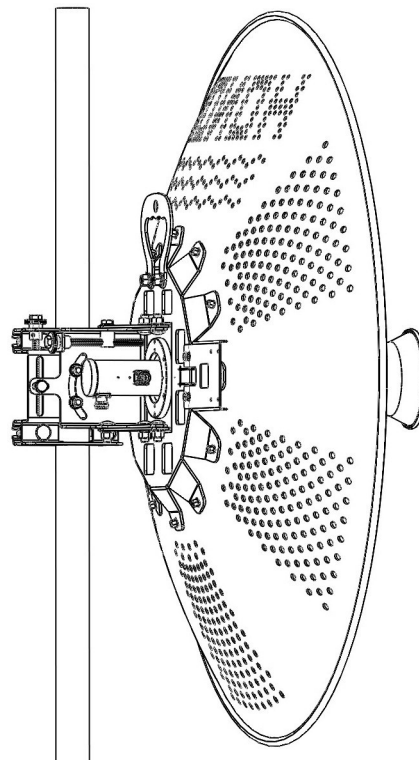
The installation, maintenance or removal of antenna systems requires qualified, experienced personnel. This installation instructions have been written for such personnel. Antenna systems should be inspected once a year by qualified personnel to verify proper installation, maintenance, and condition of equipment. Honorwave disclaims any liability or responsibility for the results of improper or unsafe installation practices.



## Tools Required

Item	Contents	Qty	Image
1	Combination Wrench, 13mm	1	
2	Screwdriver, cross-recess	1	

## Part List

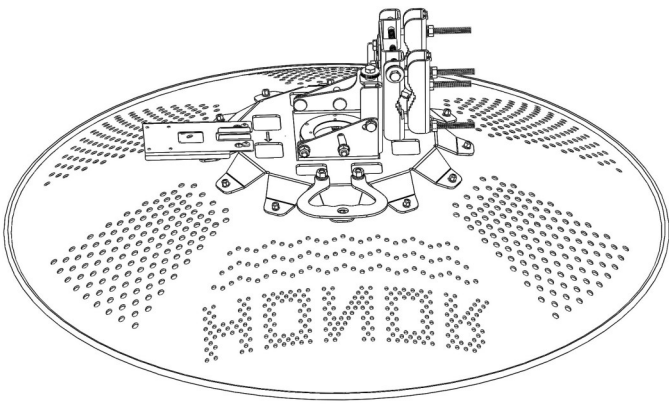
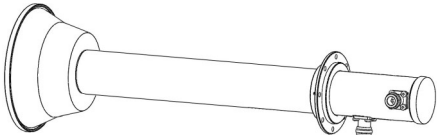
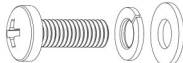
Item	Contents	Qty	Description / Image
A	Reflector 0.9m (3ft) & Mounting	1	
B	Feeder	1	
C	Screw M4x12, Cross, st	4	Feed to Reflector 
D	Spring Washer M4, st	4	
E	Washer M4, st	4	
F	Installation Guide	1	

## Installation

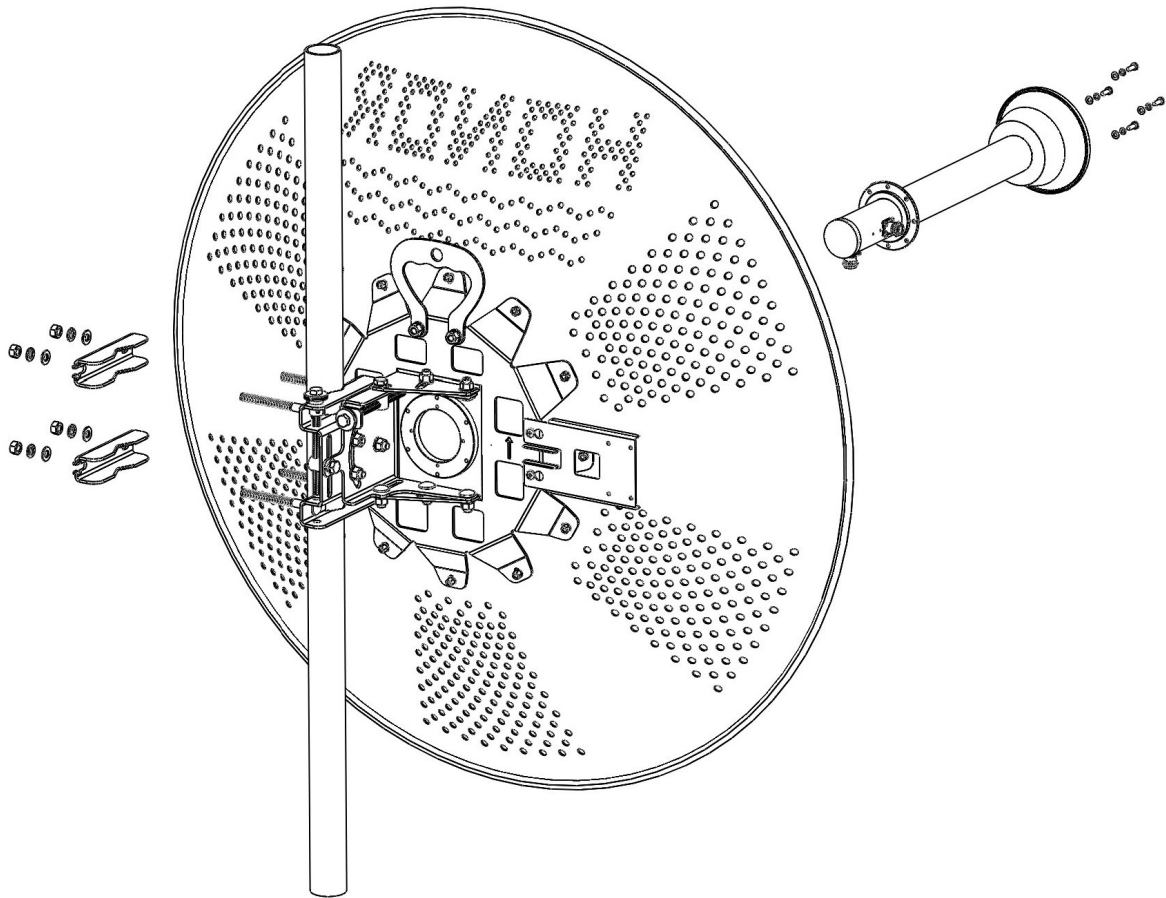

### 1 Install Feed to Reflector

Install Feed [B] to Reflector [A] by:

[C] Screw M4x12; 4 pcs

[D] Spring Washer M4; 4 pcs

[E] Washer M4; 4 pcs

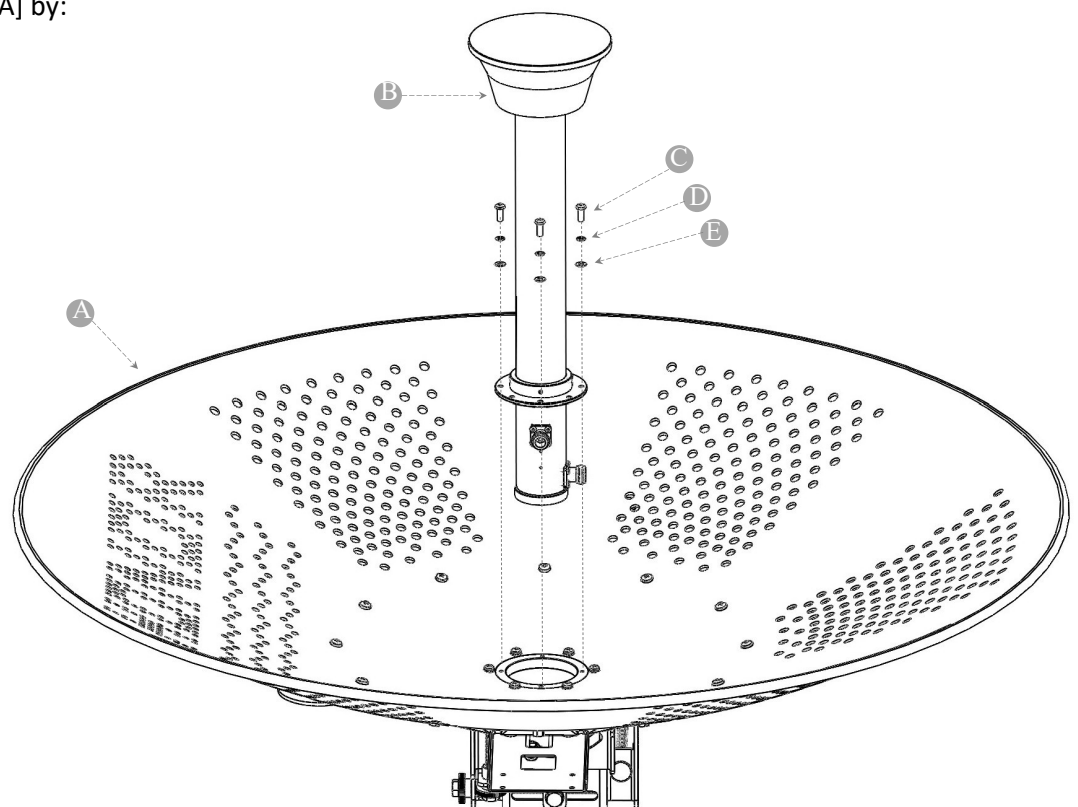

## 2 Attach Antenna to Mounting Pole

Follow the picture to attach antenna to mounting pole then place the U-bolts on the M8x120 Screws and tighten M8 nuts.

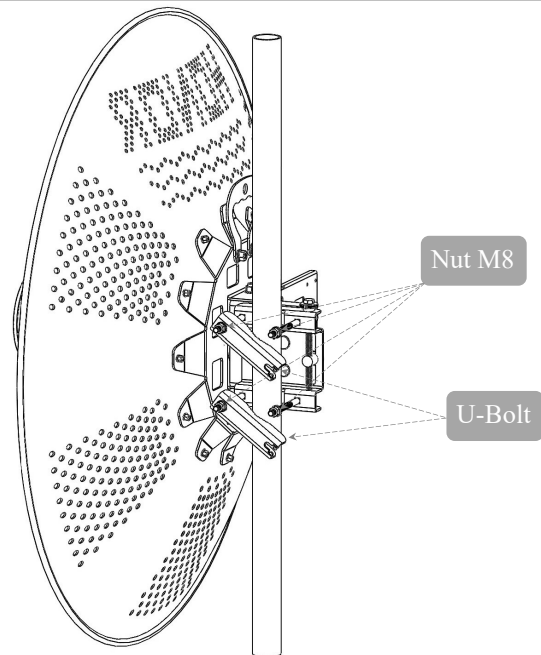

## 3 Adjust Azimuth and Elevation

After an approximate alignment, both elevation and azimuth could be precisely adjusted by tightening/loosening the elevation and azimuth screws shown in picture.

When azimuth/elevation are set, tighten all nuts to approximately 14N-m (10 lb-ft).

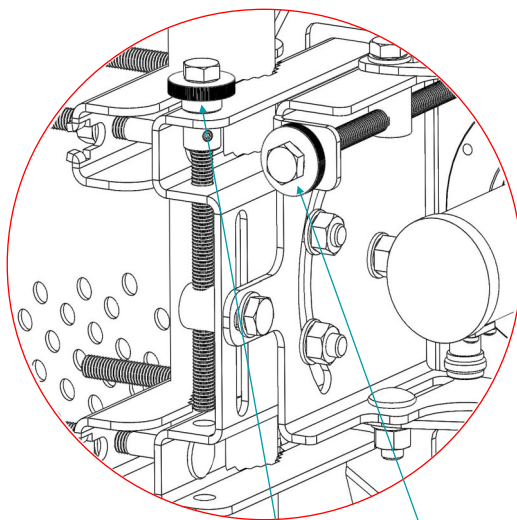

Elevation Adjustment Screw

Azimuth Adjustment Screw

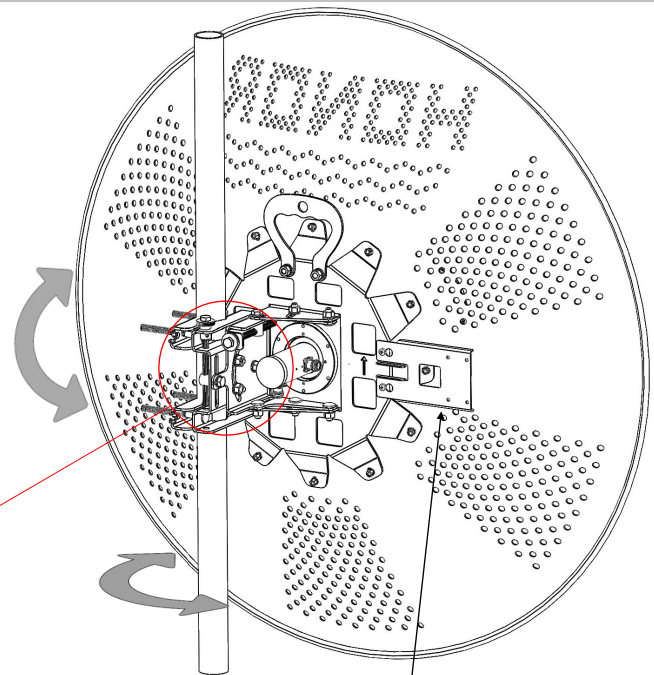

**Important:**  
The Radio Installation Plate on the Mounting bracket is to install radio box.

## TECHNICAL DATA SHEET

### General Specifications

Model Number	HW4961-32.65D-HP
Diameter (ft/m)	3/0.9
Polarization	Dual (Vertical and Horizontal)

### Electrical Specifications

Input	2 × N-Female
Frequency Range	5 GHz ISM Band
VSWR	1.4:1
Impedance ( $\Omega$ )	50
Gain (dBi)	32.65
3dB Beamwidth	H-plane: 3.4° / E-plane: 3.4°
F/B Ratio (dB)	40

### Mechanical Specifications

Weight With Holder (kg)	9.5
Color	Golden
Plating	Dacromet
Screws and Nuts	Dacromet
Fine Azimuth Adjustment	$\pm 11^\circ$
Fine Elevation Adjustment	$\pm 19^\circ$
Wind Loading (km/h)	200
Operating Temperature	-40 °C to 60 °C
Supportable Comparative Damp	90%

### Patterns

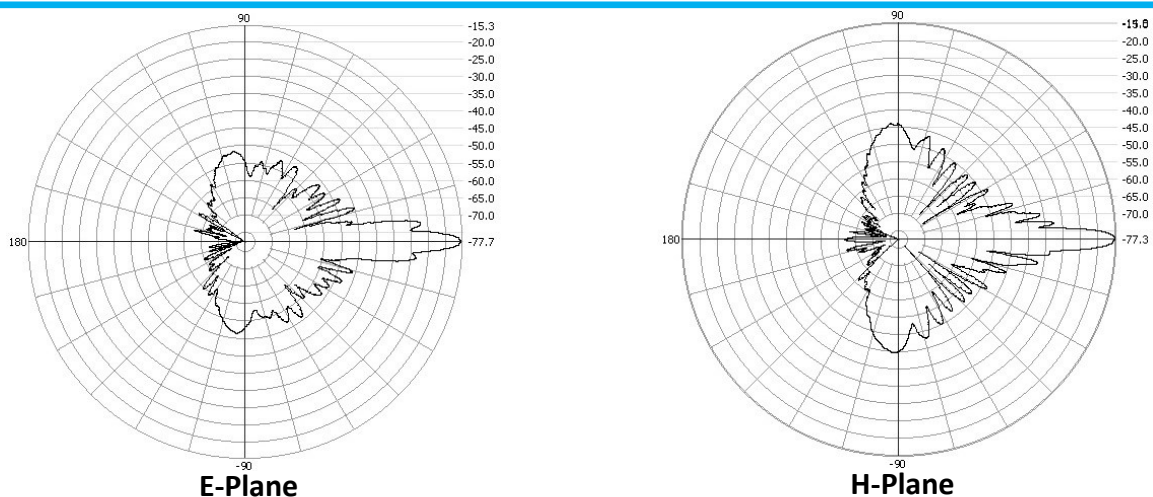

For further technical support leave message at

E-mail: [support@honorwave.com](mailto:support@honorwave.com)

whatsapp: +964 770 607 7724 8 A.M - 5 P.M (GMT+3)

All messages will be answered in 2 working days.