

Antenna Installation Instructions

Part Number: HW5971-32D-HP

Description



This antenna consists of a 0.72 m (2.4 ft) reflector, feeder and antenna mounting bracket. The mounting bracket is designed for installation on vertical pipe of diameter 35mm to 75mm. The precise antenna mounting bracket provides adjustment ranges of $\pm 19^\circ$ fine elevation and $\pm 11^\circ$ fine azimuth. Unique feature of honorwave mounting bracket is the "Radio Installation Plate". This plate makes it easy to align antenna while radio is installed on the mount.

Notice

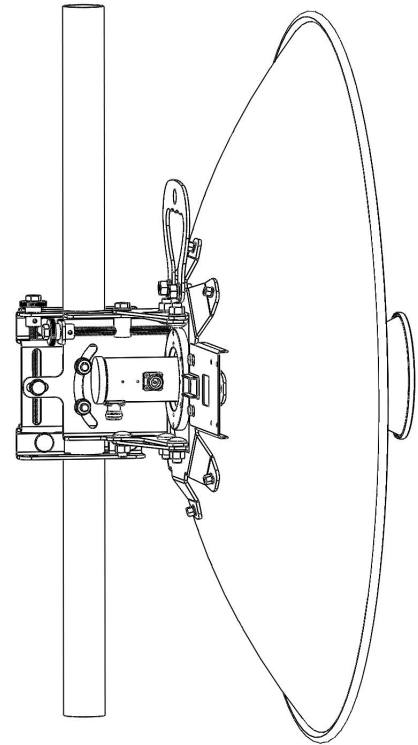
The installation, maintenance or removal of antenna systems requires qualified, experienced personnel. This installation instructions have been written for such personnel. Antenna systems should be inspected once a year by qualified personnel to verify proper installation, maintenance, and condition of equipment. Honorwave disclaims any liability or responsibility for the results of improper or unsafe installation practices.



Tools Required

Item	Contents	Qty	Image
1	Combination Wrench, 13mm	1	
2	Screwdriver, cross-recess	1	

Part List

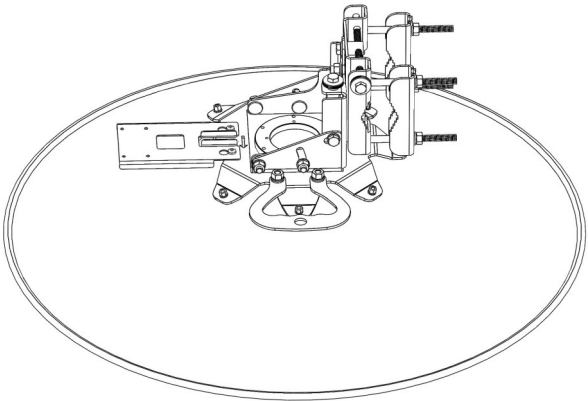
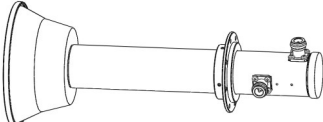
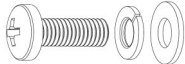
Item	Contents	Qty	Description / Image
A	Reflector 0.72m & Mounting	1	
B	Feeder	1	
C	Screw M4x12, Cross, st	4	Feed to Reflector 
D	Spring Washer M4, st	4	
E	Washer M4, st	4	
F	Installation Guide	1	

Installation

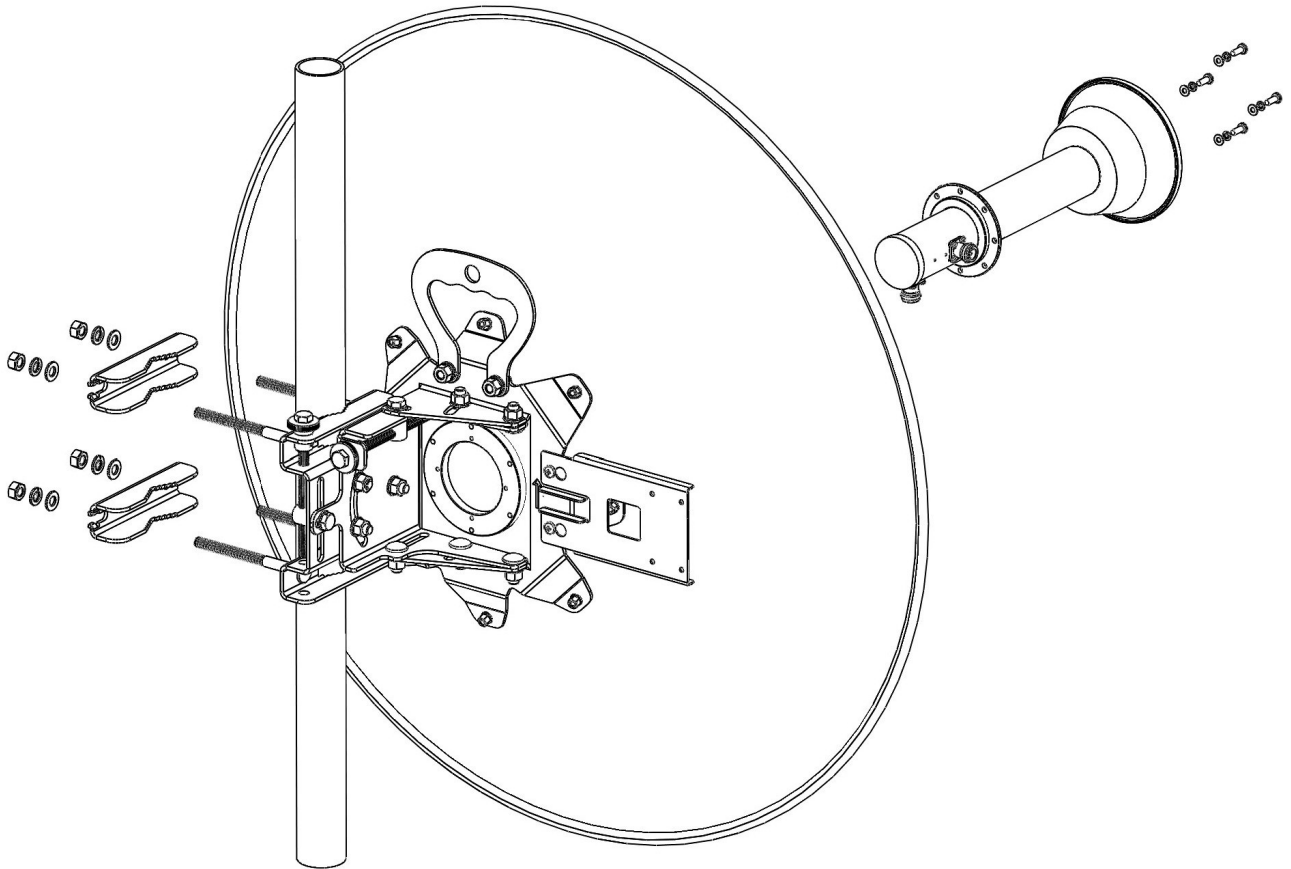

1 Install Feed to Reflector

Install Feed [B] to Reflector [A] by:

[C] Screw M4x12; 4 pcs

[D] Spring Washer M4; 4 pcs

[E] Washer M4; 4 pcs

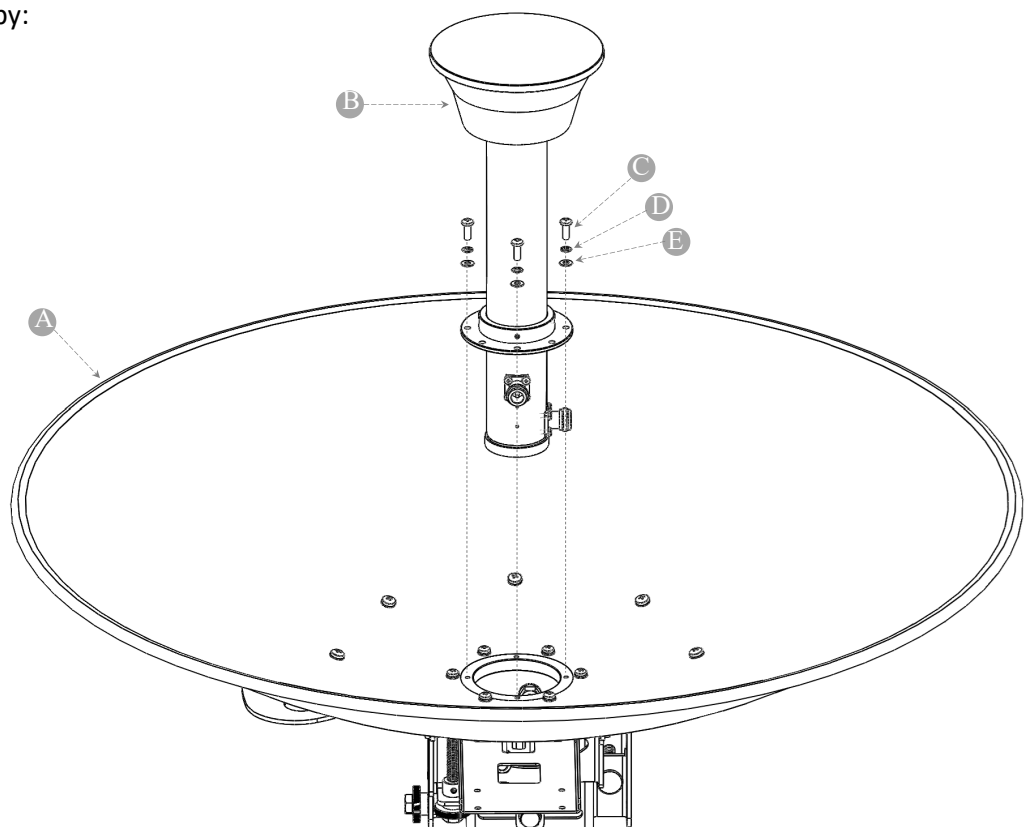

2 Attach Antenna to Mounting Pole

Follow the picture to attach antenna to mounting pole then place the U-bolts on the M8x120 Screws and tighten M8 nuts.

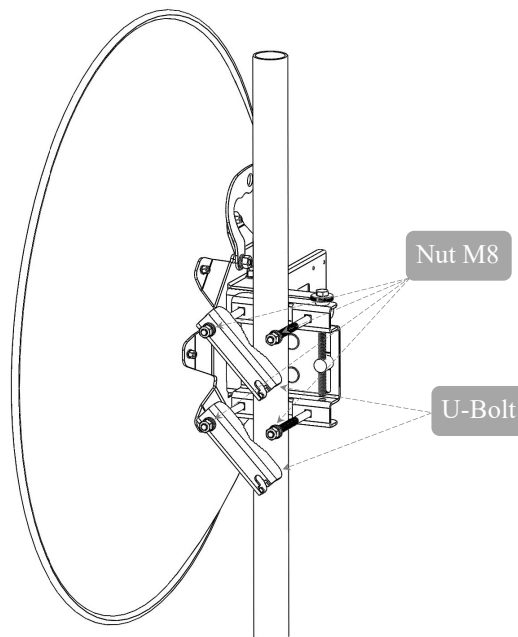

3 Adjust Azimuth and Elevation

After an approximate alignment, both elevation and azimuth could be precisely adjusted by tightening/loosening the elevation and azimuth screws shown in picture.

When azimuth/elevation are set, tighten all nuts to approximately 14N-m (10 lb-ft).

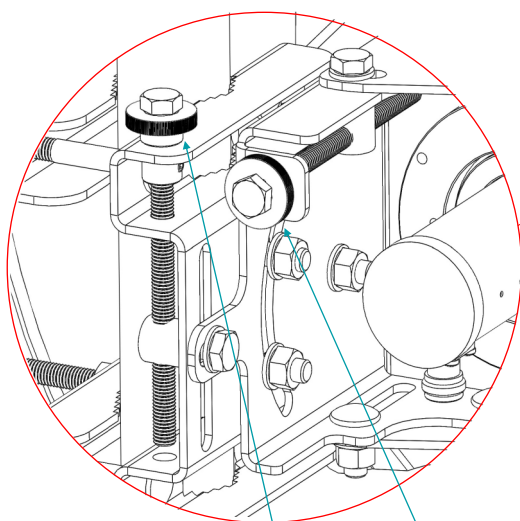

Elevation Adjustment Screw

Azimuth Adjustment Screw

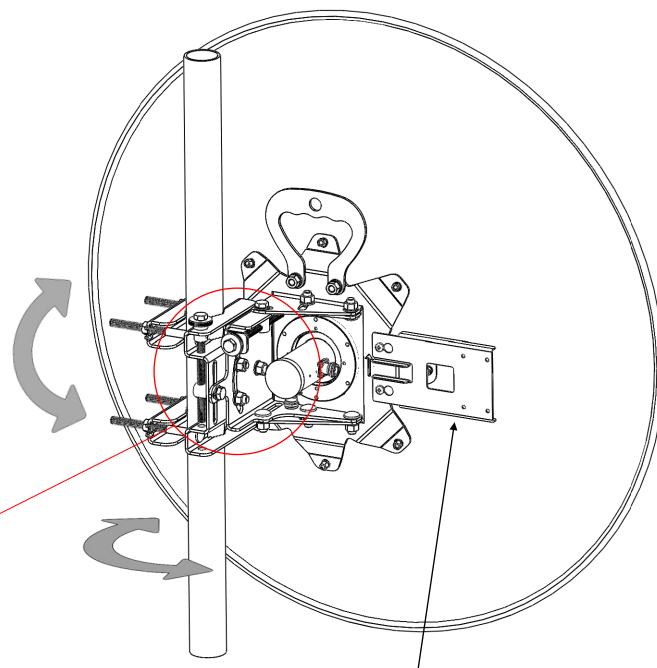

Important:
The Radio Installation Plate on the Mounting bracket is to install radio box.

TECHNICAL DATA SHEET

General Specifications

Model Number	HW5971-32D-HP
Diameter (ft/m)	2.4/0.72
Polarization	Dual (Vertical and Horizontal)

Electrical Specifications

Input	2 × N-Female
Frequency Range	5.925 GHz to 7.125 GHz
VSWR	1.4:1
Impedance (Ω)	50
Gain (dBi)	32
3dB Beamwidth	H-plane: 3.6° / E-plane: 3.6°
F/B Ratio (dB)	40

Mechanical Specifications

Weight With Holder (kg)	5.5
Color	Golden
Plating	Dacromet
Screws and Nuts	Dacromet
Fine Azimuth Adjustment	$\pm 11^\circ$
Fine Elevation Adjustment	$\pm 19^\circ$
Wind Loading (km/h)	200
Operating Temperature	-40 °C to 60 °C
Supportable Comparative Damp	90%

Patterns

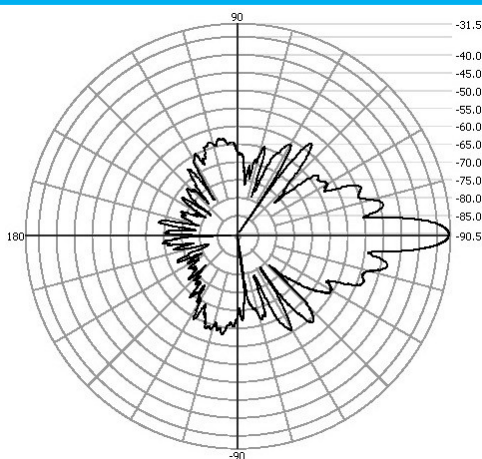

E-Plane

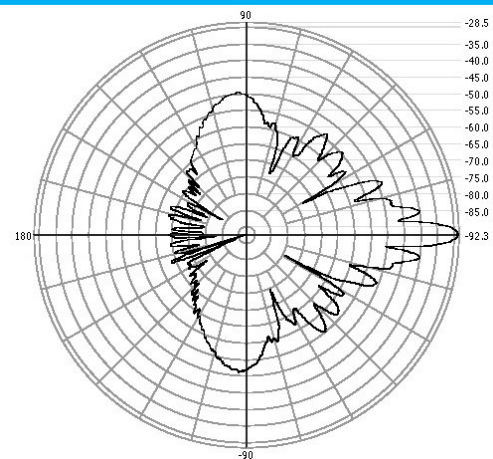

H-Plane

For further technical support leave message at

E-mail: support@honorwave.com

whatsapp: +964 770 607 7724 8 A.M - 5 P.M (GMT+3)

All messages will be answered in 2 working days.